

Instrucciones de montaje

Faja cartón europalet

Contiene

x2



x1

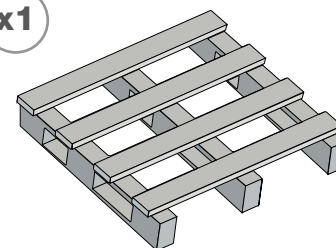

1

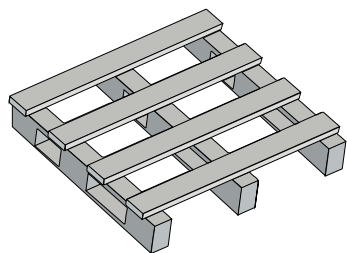

Colocar el pallet en el lugar deseado

2

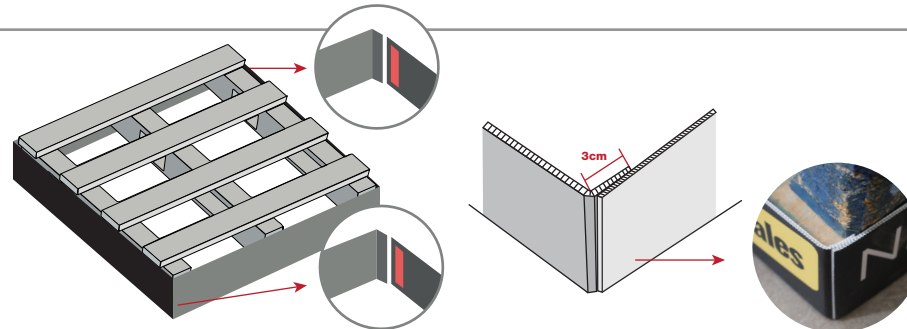

Retirar el protector del adhesivo y unir las dos piezas

3



Coloca los productos